



Ny S-Klasse

September 2020

Mercedes-Benz



Den nye S-Klasse

Velkommen

Velkommen til den seneste udgave af den ikoniske Mercedes-Benz S - Klasse. Her kan du læse meget mere om standard og ekstraudstyr.

S-Klassen er og bliver "midtpunktet" og det ikke kun inden for Mercedes-Benz-modelprogrammet, men den er også referencepunkt og foregangsbillede i hele den internationale bilindustri. S-klassen er også foregangsbil med en stribe unikke benchmark. Og denne S-klasse er lige så tro i denne rolle som de fremtrædende og succesrige forgængere, S-klassen sætter nye benchmarks inden for moderne luksus, komfort og sikkerhed.



Den nye S-Klasse

Højdepunkter

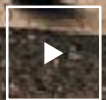



Moderne luksus

S-Klassens interiør er et stilikon, der bringer moderne luksus op på det næste niveau. Set fra en rationel side så fungerer designet både som en trailblazer og som en retningslinje for fremtidige modeller. Det repræsenterer den fortsatte videreudvikling af den sensuelle, rene og enkle designfilosofi og fører den videre ind i fremtiden blandt de absolutte luksusbiler.

Se alt!

Det nye unikke DIGITAL LIGHT fungerer som en projector med mere end en million pixels per forlygte og giver krystalklart lys på vejen uanset tidspunkt og vejrforhold. ULTRA RANGE fjernlyset lyser 650 m frem – og gør nat til dag!

Køreoplevelse

Den nye S-klasse er den perfekte kombination af komfort, præcision og dynamik.

Oplev den fulde førsteklases komfort med den fuldt aktive luftundervogn, uanset om det er motorvej, kurverig sognevej eller grusvej.

Som ekstraudstyr kan leveres aktiv bagakselstyring som formindsker venderadiusen med næsten 2 meter. Så føles en S-klasse som en kompakt hatchback.

Ved høj fart er der total ro i bilen med sublim komfort og stabilitet også takket være den lange akselafstand.





Mobilt Wellnesscenter

Den nye S-klasse kan også tilbyde en stribe af ENERGIZING massager. Sammen med AIR-BALANCE pakken, er luftkvaliteten forbedret med ionization og delikate dufte takket være den integrerede Mercedes-Benz parfumeholder integreret i hanskerummet.



Mærk musikken

Du kan også mærke musikken med alle sanser hvis du vælger det unikke Burmester® High-End 4D surround sound system, som yder op til 1.750 Watts. Denne nye dimension kommer takket være 30 high-end højtalere, inklusive 2 Frontbass woofers, en ekstra subwoofer og 8 stemningsgivere integreret i sædet for en helt unik musikoplevelse!

Swipe!

Med den nye krystallklare OLED 12,3" centerskærm eller, som ekstraudstyr, MBUX tabletten på 7" bag, kan du altid kontrollere din S-klasse med fingerspidserne. Her kontrolleres din destination, underholdning og komfort enkelt og intuitivt.



Den nye S-Klasse

Varianter



Vælg din variant



Standard

Cutting-edge teknologi, højeste niveau af komfort og enestående luksus – det er den nye Mercedes-Benz S-klasse!

AMG

Med AMG pakken giver du et klart sportsligt udtryk, både udvendigt og indvendigt.



Standardudstyr

-
- 18" 5-twin-eger letmetalfælge
 - Førerassistentpakke PLUS med PRESAFE Sound
 - MBUX Navigation Premium
 - Augmented reality
 - 12,8" OLED Touchscreen med haptisk feedback
 - Trådløs opladning for
 - Digital radio
 - Oplyste trinlister og projektering af logo
 - Skilteassistent
 - PRE-SAFE® system
 - KEYLESS-GO med skjulte dørhåndtag
 - Soft close
 - Memory sæder for
 - MAGIC VISION CONTROL med opvarmede viskerblade
 - Velourmåtter
 - AIRMATIC affjedring



Advantagepakke

standard i DK

- 1 413 – Panorama soltag
- 2 451 – Instrumentdisplay i 3D
- 3 878 – Aktiv ambiente belysning (lysstribe med aktive funktioner for stemmestyring og førerassistent)
- 4 PBH – Parkingspakke med remote parkingsfunktion inkl. 360° kamera
- 5 27U – Forberedelse for INTELLIGENT PARKERINGSPILOT*
- 6 P82 – Tyveripakke PLUS
- 7 810 – Burmester® 3D surround sound system (15 høj kvalitetshøjtalere inklusive 2 forreste bass-woofers med et totalt output på 710 Watts)
- 32U – Personlig optimeret lydbillede

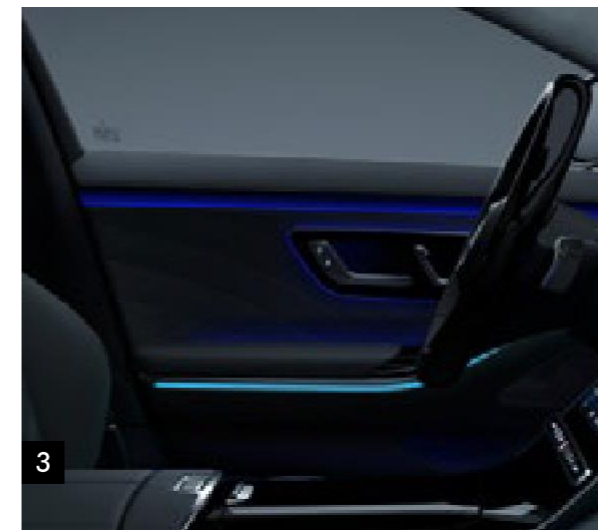

*Use of the function by customers is only possible when national legislation permits operation of Automated Valet Parking (AVP), the multi-storey car parks are fitted with the corresponding AVP technology and the corresponding Mercedes me connect service has also been booked.



Premiumpakke

standard i DK

Advantage pakke



- 1** 318 – DIGITAL LIGHT (HD system med projecteringsmodul med mere end 1 million pixels pr. lygte) med adaptiv fjernlysassistent PLUS
- 2** 445 – MBUX augmented reality Head-up Display
- 3** 432 – Aktiv multikontursædepakke inklusive ekstra nakkepude
(med massagefunktion, dynamisk support og PRE-SAFE® position)
- 4** 401 – Klimasæder, for



Standard

AMG



Forkofanger, sideskørter og bagkofanger med kromindsats



868 - 12,8" OLED Touchscreen med
haptisk feedback og augmented reality



318 - Digitallys



L2B - Multifunktionsrat i nappalæder



889 - KEYLESS-GO med skjulte dørhåndtag

Standard

Letmetalfælge

S 350 d og S 400 d



01R – 18" letmetalfælge i dobbelt 5-eget design - **Standard**



77R – 19" letmetalfælge i dobbelt fem-eget design - **ekstraudstyr**



R55 – 19" letmetalfælge i dobbelt 5-eget design - **ekstraudstyr**



R60 – 19" letmetalfælge i dobbelt multieget design - **ekstraudstyr**



15R – 19" letmetalfælge i dobbelt multieget design - **ekstraudstyr**



R42 – 20" letmetalfælge i dobbelt multieget design - **ekstraudstyr**



60R – 20" letmetalfælge i multieget design - **ekstraudstyr**



R73 – 20" letmetalfælge i dobbelt 10-eget design, smedet **ekstraudstyr**

Fælg	Dækstørrelse
18"	255/50
19"	255/45
20"	255/40

Standard

Letmetalfælge

S500 4MATIC



77R - 19" letmetalfælge i dobbelt fem-eget design - **ekstraudstyr**



R55 - 19" letmetalfælge i dobbelt 5-eget design - **ekstraudstyr**



R60 - 19" letmetalfælge i dobbelt multieget design - **Standard**



15R - 19" letmetalfælge i dobbelt multieget design - **ekstraudstyr**



R42 - 20" letmetalfælge i dobbelt multieget design - **ekstraudstyr**



60R - 20" letmetalfælge i multieget design - **ekstraudstyr**



R73 - 20" letmetalfælge i dobbelt 10-eget design, smedet - **ekstraudstyr**

Fælg	Dækstørrelse
19"	255/45
20"	255/40

Standard

Indtræk

Læder



201A – Sort
Standard



204A – Sienna
brun/sort
Ekstraudstyr



205A – Macchiato
beige/magma grå
Ekstraudstyr

Læder Nappa



801A* – Sort
**Inkl. i PYO
Premiumpakke
PLUS**



804A – Sienna
brun/sort
Ekstraudstyr



805A – Macchiato
beige/magma grå
Ekstraudstyr

Læder Nappa Exclusive



501A – Sort
Inkl. i P34



504A – Sienna
brun/sort **Inkl. i P34**



505A – Macchiato
beige/magma grå
Inkl. i P34



507A – Carmine
rød/sort – **Inkl. i
P34****



508A – sølv grå/sort
Inkl. i P34

	Læder	NAPPA	NAPPA EXCLUSIVE
Sæder	Læder	Nappa	Nappa
Design	Waterfall	Diamond	Diamond
Perforeret	Kun med klimasæder for	Ja	Ja
Dørpaneler	Artico	Artico with diamond stitching	Nappa with diamond stitching
Øverste del af i-bord	Artico	Artico	Nappa
Øverste dørbekl.	Artico	Artico	Nappa
Taghimmel & solskærme	Stof	Stof	DINAMICA

**Ikke med udv. farve 998U/989U.

Standard

Taghimmel

Stof



51U - Sort - **Standard med indtræk:**
201A/204A/801A/804A



55U - Beige - **Standard med indtræk:** 205A/805A



58U - Neva grå
Ekstraudstyr (0 kr.),
kun i forb. med indtræk
201A/801A

DINAMICA



61U - Sort - **Inkl. i P34 + 501A/504A/507A,**
Ekstraudstyr med 508A



68U - Neva grå - **Inkl. i forb.**
med 508A, Ekstraudstyr i
forb. med P34 + 501A



65U - Beige - **Inkl. i P34 + 505A**

Rat



L2B - Multifunktionsrat i Nappa
Læder - **Standard**



L2D - Multifunktionsrat i træ/læder
- **Ekstraudstyr**

Standard

Midterkonsol



726 - Midterkonsol i blank sort - **standard**



722 - Midterkonsol i sort med sølveffekt
Ekstraudstyr*

Interiørlister



H02 - Interiørlister i antracit åbenporet poppeltræ - **Standard**



H29 - Interiørlister i brun højglans valnøddetræ - **ekstraudstyr**



H37 - Interiørlister i sort højglans poppeltræ - **ekstraudstyr**



H75 - Interiørlister i sort/sølv med metalsølv effekt - **ekstraudstyr**



H17 - designo interiørlister i sort pianolak, flowing lines
ekstraudstyr



H38 - designo interiørlister i brun åbenporet valnøddetræ, aluminium**
ekstraudstyr

*Kun i forb. med interiørliste H75

** Kun i forb. med Nappa Læder.



AMG

AMG styling indeholdende :

- AMG skørt for
- AMG skørt bag med diffuser-look og indsats i krom
- Synlig udstødningselement i krom
- Sideskørt med indsats i krom

19" AMG 5-eget letmetalfælg (RZ1)

Multifunktionssportsrat i nappalæder (L5C)

AMG pedaler i børstet rustfrit stål med gummi-prikker.

AMG velour bundmætter (U26)

Varmeisolerende mørk-tonede ruder bag (840)

Forstærkede bremses med større bremseskiver (U29)

Billede viser en bil uden tonede ruder bag



Billede viser en bil uden tonede ruder bag



Billede viser interiørliste H37 som er ekstraudstyr

AMG



Med AMG pakken får din S-klasse et klart dynamisk og sportslig udtryk, både ind- og udvendigt.



RZ1 - 19" AMG letmetalfælge i dobbelt 5-eget design



Bilen er vist med interiørliste H37 som ekstraudstyr

L5C - Multifunktionsrat i nappalæder med fladbund



840 - Varmeisolerende og mørktonede ruder



U26 - AMG bundmætter samt sportspedaler

AMG

Letmetalfælge



RRG/RZI* – 19" AMG
letmetalfælge i dobbelt 5-eget
design – **RZI er standard**
(RRG i forb. 216 bagakselstyring)



RVU/RVQ* – 20" AMG
letmetalfælge i
multieget design
ekstraudstyr



RVV/RVR* – 20" AMG
letmetalfælge i multieget
design i sort
ekstraudstyr



RWN* – 21" AMG
letmetalfælge i multieget
design i sort **
ekstraudstyr



RWK* – 21" AMG letmetalfælge i
multieget design **
ekstraudstyr

FÆLG	DÆK NORMAL	*MIXED DÆKMONTERING FOR/BAG
19"	255/45	255/45 (for) og 285/40 (bag)
20"	255/40	255/40 (for) og 285/35 (bag)
21"	-	255/35 (for) og 285/30 (bag)

****) 216 bagakselstyring er ikke
mulig med mixed dækmontering
for/bag***

******) 21" letmetalfælge ikke i forbindelse med 216 bagakselstyring***

Indtræk

Læder



201A – Sort
Standard

204A – Sienna
brun/sort
Ekstraudstyr

205A – Macchiato
beige/magma grå
Ekstraudstyr

Læder Nappa



801A* – Sort
**Inkl. i PYO
Premiumpakke
PLUS**

804A – Sienna
brun/sort
Ekstraudstyr

805A – Macchiato
beige/magma grå
Ekstraudstyr

Læder Nappa Exclusive



501A – Sort
Inkl. i P34

504A – Sienna
brun/sort **Inkl. i P34**

505A – Macchiato
beige/magma grå
Inkl. i P34



507A – Carmine
rød/sort – **Inkl. i
P34****

508A – sølv grå/sort
Inkl. i P34

	Læder	NAPPA	NAPPA EXCLUSIVE
Sæder	Læder	Nappa	Nappa
Design	Waterfall	Diamond	Diamond
Perforeret	Kun med klimasæder for	Ja	Ja
Dørpaneler	Artico	Artico with diamond stitching	Nappa with diamond stitching
Øverste del af i-bord	Artico	Artico	Nappa
Øverste dørbekl.	Artico	Artico	Nappa
Taghimmel & solskærme	Stof	Stof	DINAMICA

**Ikke med udv. farve 998U/989U.

Taghimmel

Stof



51U - Sort - **Standard med indtræk:**
201A/204A/801A/804A



55U - Beige - **Standard med indtræk:** 205A/805A



58U - Neva grå
Ekstraudstyr (0 kr.), kun med indtræk
201A/801A

DINAMICA



61U - Sort - **Inkl. i P34 + 501A/504A/507A,**
Ekstraudstyr med 508A



65U - Beige - **Inkl. i P34 + 505A**



68U - Neva grå - **Inkl. i forb. med 508A,**
Ekstraudstyr i forb. med P34 + 501A

Rat



L5C - Multifunktionssportsrat i Nappa Læder - **Standard**



L2D - Multifunktionsrat i træ/læder - **Ekstraudstyr**

Standard

Midterkonsol



726 - Midterkonsol i blank sort - **standard**



722 - Midterkonsol i sort med sølveffekt
Ekstraudstyr*

Interiørlister



H02 - Interiørlister i antracit åbenporet poppeltræ - **Standard**



H29 - Interiørlister i brun højglans valnøddetræ - **ekstraudstyr**



H37 - Interiørlister i sort højglans poppeltræ - **ekstraudstyr**



H75 - Interiørlister i sort/sølv med metalsølv effekt - **ekstraudstyr**



H17 - designo interiørlister i sort pianolak, flowing lines
ekstraudstyr



H38 - designo interiørlister i brun åbenporet valnøddetræ, aluminium**
ekstraudstyr

*Kun i forb. med interiørliste H75

** Kun i forb. med Nappa Læder.

Den nye S-Klasse

Motorer



Diesel

	BM	Ydelse i kW (hk)	Størrelse in cm ³	CO ₂	Transmission	
S 350 d	223.030	210 (286)	2.925	176	9G-TRONIC automatic	
S 350 d 4MATIC	223.031	210 (286)	2.925	181	9G-TRONIC automatic	
S 400 d 4MATIC	223.033	243 (330)	2.925	181	9G-TRONIC automatic	

Diesel - Lang

		Ydelse i kW (hk)	Størrelse i cm ³	CO ₂	Transmission	
S 350 d	223.130	210 (286)	2.925	178	9G-TRONIC automatic	
S 350 d 4MATIC	223.131	210 (286)	2.925	182	9G-TRONIC automatic	
S 400 d 4MATIC	223.133	243 (330)	2.925	182	9G-TRONIC automatic	

Benzin

	<u>BM</u>	<u>Ydelse kW (hk)</u>	<u>Størrelse i cm³</u>	<u>Transmission</u>
<u>S500 4MATIC</u>	<u>223.063</u>	<u>320/16 (435)</u>	<u>2.999</u>	<u>9G-TRONIC automatic</u>

Benzin - Lang

	<u>BM</u>	<u>Ydelse kW (hp)</u>	<u>Størrelse i cm³</u>	<u>Transmission</u>
<u>S500 4MATIC</u>	<u>223.163</u>	<u>320/16 (435)</u>	<u>2.999</u>	<u>9G-TRONIC automatic</u>

Den nye S-Klasse

Ekstraudstyr





Pakker

Premiumpakke Plus

(PYO)

Executivepakke, bag

(PYP)

Businessklasse

(PYS)

Premiumpakke Plus

Kode PYO



- 1 801A - Sort Nappalæder
- 2 872 - Sædevarme, bag*
- 3 PBP - ENERGIZING Comfort, for
- 4 P21 - AIR-BALANCE pakke (parfumeholder med ionisation funktion)*
- 4 P69 - Varme komfortpakke (opvarmet rat og armlæn)*

Pris: 25.000 kr



*Billede blot for illustration, viser ikke S-Klasse

Executive bagsædepakke

Kode PYP

- 1 447 – MBUX bagsæde tablet
- 2 402 – Klimasæder med ventilation og varme, bag
- 3 561 – Designer selelåse for og bag
- 4 582 – THERMOTRONIC automatisk klimaanlæg bag (2-zoner) P09 –
- 5 Solbeskyttelsespakke*
- 6 223 – Bagsæder med el-justerbare yderpladser (3 siddepladser), inkl. memory
- 7 P07 – Chaufførpakke, kan give mere benplads til bagsædepassagerer
- 898 – Trådløs opladning, bag

Pris: 150.000 kr

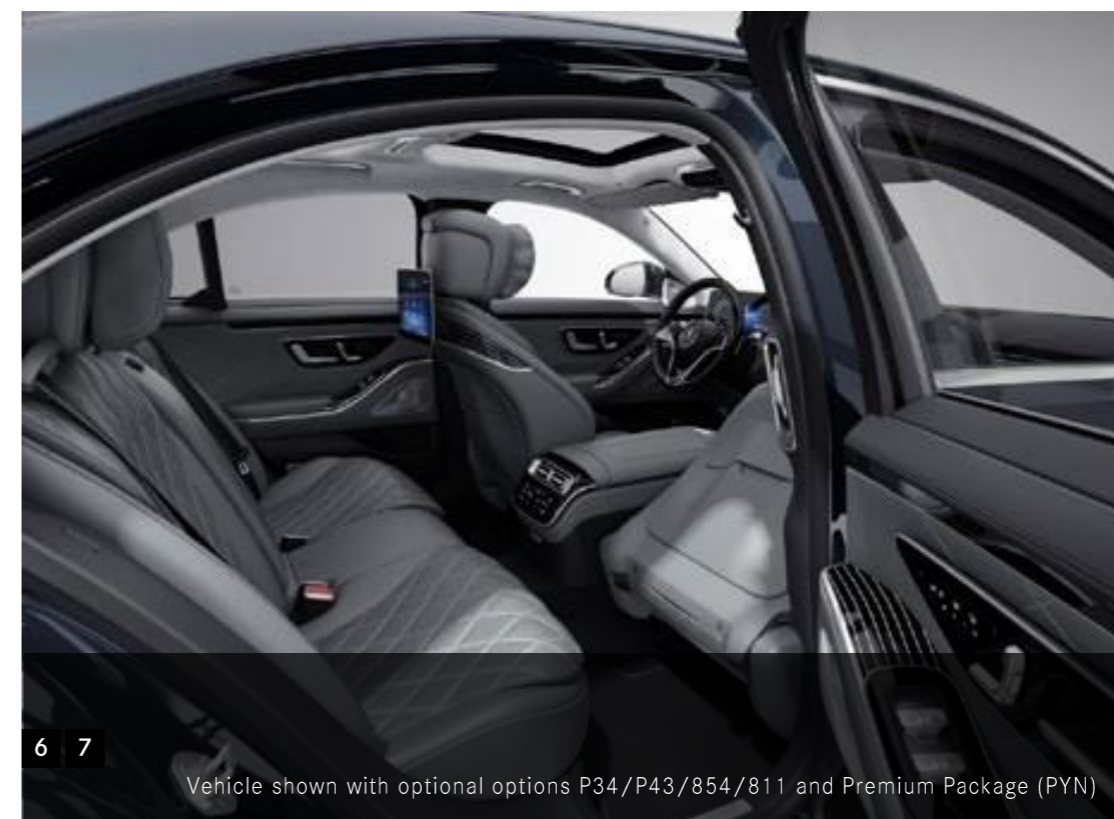

Business Class

Kode PYS, kun mulig til lang version

Premiumpakke Plus



Executive bagsædepakke



- 1 854 – MBUX High-End bagsædeunderholdning med touchskærme
- 2 453 – Executivebagsæder med op til 43,5° hældning og benstøtte
- 3 865 – TV modtager
- 4 811 – Burmester® high-end 4D surround sound system med 30 high-end højtalere inklusive 2 Frontbass woofers + 1 subwoofer + 8 stemningsenheder i sæderne (total ydelse 1750 watts)
- 5 U58 – 2 trådløse head sets
- 6 306 – Seleairbags & sideairbags bag
- 302 – Airbags bag (monteret i forsæderyggen)
- PBT - ENERGIZING Komfortpakke bag inklusive massagesæder

Pris: 370.000 kr

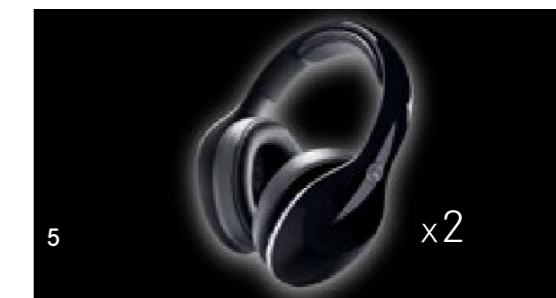

Eksklusivpakke

Kode P34

- Eksklusiv nappalæder (500A)
- Øverste instrumentbordsdel, dørpaneler, armlæn og fartgreb i nappalæder
- Eksklusiv trimpakke med ekstra trimdele bagpå forsæderne
- Tagstof og solskærme beklædt med DINAMICA
- Bundmåtter med kontrastfarvede kanter (U04) – ikke for AMG
- Bagagerumskant i rustfrit stål

Pris kun i forbindelse med Premiumpakke PLUS (PYO) eller Business Class pakke (PYS): 89.500 kr



Bilen er vist med Executive bagsædepakke (PYP - ekstraudstyr)





AMG

AMG styling indeholdende :

- AMG skørt for
- AMG skørt bag med diffuser-look og indsats i krom
- Synlig udstødningselement i krom
- Sideskørt med indsats i krom

19" AMG 5-eget letmetalfælg (RZ1)

Multifunktionssportsrat i nappalæder (L5C)

AMG pedaler i børstet rustfrit stål med gummi-prikker.

AMG velour bundmætter (U26)

Varmeisolerende mørk-tonede ruder bag (840)

Forstærkede bremses med større bremseskiver (U29)

Pris: 130.000 kr

Billede viser en bil uden tonede ruder bag



Billede viser en bil uden tonede ruder bag



Billede viser interiørliste H37 som er ekstraudstyr

Nightpakke

Kode P55, kun med AMG

- 1 Frontsplitter og finner i luftindtag i sort højglans
- 2 Sidepaneler med indsats i sort højglans
- 3 Trimelement i bagkofanger i sort højglans
- 4 Spejlhuse i sort højglans

Pris: 8.500 kr



2 4



1



3

Lakering



040U – Sort



Metallak

197U – Obsidian Sort



Metallak

346U – Onyx Sort



Metallak

998U – Anthracite Blå



Metallak

859U – Mojave sølv



Metallak

989U – Emerald grøn



Metallak

831U – Graphite grå



Metallak

992U – Selenite grå



Metallak

660U – Rubelite rød



Metallak

922U – Hightech sølv



designo

799U – *designo* diamond hvid

Den nye S-Klasse

Tekniske data



Tekniske data - kort udgave

	S350d	S350d 4MATIC	S400d 4MATIC	S500 4MATIC
MODEL VARIANT NUMBER	223.030	223.031	223.033	223.063
ENGINE				
Arrangement of cylinders	L6	L6	L6	L6
Numbers of valves per cylinder	4	4	4	4
Displacement (cc)	2.925	2.925	2.925	2.999
Rated output (kW [hp] at rpm)	210 [286]/3.400 - 4.600	210 [286]/3.400 - 4.600	243 [330]/3.600 - 4.200	320 [435]/6.100 - 6.100
Rated torque (Nm at rpm)	600/1.200 - 3.200	600/1.200 - 3.200	700/1.200 - 3.200	520/1.800 - 5.800
Tank capacity/reserve (l)	76/8	76/8	76/8	76/8
TRANSMISSION				
	9G-TRONIC	9G-TRONIC	9G-TRONIC	9G-TRONIC
PERFORMANCE				
Top speed (km/h)	250	250	250	250
Acceleration 0-100 km/h (s)	6,4	6,2	5,4	4,9
CONSUMPTIONS AND EMISSION				
[NEDC] Combined fuel consumption l/100 km (dependent on chosen Ekstraudstyr equipment)	6,7 - 6,2	6,8 - 6,3	6,9 - 6,4	9,7 - 7,8
[NEDC] Combined CO ₂ emissions g/km (dependent on chosen Ekstraudstyr equipment)	176 - 163	180 - 166	183 - 169	221 - 178
[WLTP] Combined fuel consumption l/100 km (consumption dependent on chosen Ekstraudstyr equipment)	7,6 - 6,4	7,9 - 6,5	7,9 - 6,7	10,1 - 8,0
[WLTP] Combined CO ₂ emissions g/km (consumption dependent on chosen equipment)	201 - 168	209 - 171	209 - 175	230 - 181
[NEDC] Purely electric range min. (km)	-	-	-	-
[NEDC] Purely electric range max. (km)	-	-	-	-
[WLTP] Purely electric range (km)	-	-	-	-
EMISSION CLASS				
	EURO 6D-ISC-FCM	EURO 6D-ISC-FCM	EURO 6D-ISC-FCM	EURO 6D-ISC-FCM
WEIGHT AND DIMENSIONS				
Kerb weight/payload (kg)	2.020/700	2.070/700	2.070/700	2.045/765
Maximum roof load (kg)	100	100	100	100
Perm. trailer load unbraked/braked [at 12%]/braked [at 8%] (kg)	750/2.100/-	750/2.100/-	750/2.100/-	750/2.100/-
Trunk space (l, min/max)	540 - 405*	540 - 405*	540 - 405*	550 - 405*

*Trunk space reduced with options 811/550/490/308/E69/223.

Tekniske data - lang udgave

	S350d	S350d 4MATIC	S400d 4MATIC	S500 4MATIC
MODEL VARIANT NUMBER	223.130	223.131	223.133	223.163
ENGINE				
Arrangement of cylinders	L6	L6	L6	L6
Numbers of valves per cylinder	4	4	4	4
Displacement (cc)	2.925	2.925	2.925	2.999
Rated output (kW [hp] at rpm)	210 [286]/3.400 - 4.600	210 [286]/3.400 - 4.600	243 [330]/3.600 - 4.200	320 [435]/6.100 - 6.100
Rated torque (Nm at rpm)	600/1.200 - 3.200	600/1.200 - 3.200	700/1.200 - 3.200	520/1.800 - 5.800
Tank capacity/reserve (l)	76/8	76/8	76/8	65/8
TRANSMISSION	9G-TRONIC	9G-TRONIC	9G-TRONIC	9G-TRONIC
PERFORMANCE				
Top speed (km/h)	250	250	250	250
Acceleration 0-100 km/h (s)	6,4	6,2	5,4	4,9
CONSUMPTIONS AND EMISSION				
[NEDC] Combined fuel consumption l/100 km (dependent on chosen Ekstraudstyr equipment)	6,7 - 6,2	6,9 - 6,4	7,0 - 6,5	9,7 - 7,8
[NEDC] Combined CO ₂ emissions g/km (dependent on chosen Ekstraudstyr equipment)	176 - 163	183 - 168	186 - 171	221 - 179
[WLTP] Combined fuel consumption l/100 km (consumption dependent on chosen Ekstraudstyr equipment)	7,8 - 6,5	8,0 - 6,6	8,0 - 6,7	10,1 - 8,0
[WLTP] Combined CO ₂ emissions g/km (consumption dependent on chosen equipment)	204 - 170	211 - 172	211 - 176	230 - 181
[NEDC] Purely electric range min. (km)	-	-	-	-
[NEDC] Purely electric range max. (km)	-	-	-	-
[WLTP] Purely electric range (km)	-	-	-	-
EMISSION CLASS	EURO 6D-ISC-FCM	EURO 6D-ISC-FCM	EURO 6D-ISC-FCM	EURO 6D-ISC-FCM
WEIGHT AND DIMENSIONS				
Kerb weight/payload (kg)	2.040/725	2.090/725	2.090/725	2.065/755
Maximum roof load (kg)	100	100	100	100
Perm. trailer load unbraked/braked [at 12%]/braked [at 8%] (kg)	750/2.100/-	750/2.100/-	750/2.100/-	750/2.100/-
Trunk space (l, min/max)	540 - 405*	540 - 405*	540 - 405*	550 - 405*

*Trunk space reduced with options 811/550/490/308/E69/223.

S-Klasse - kort Dimensioner

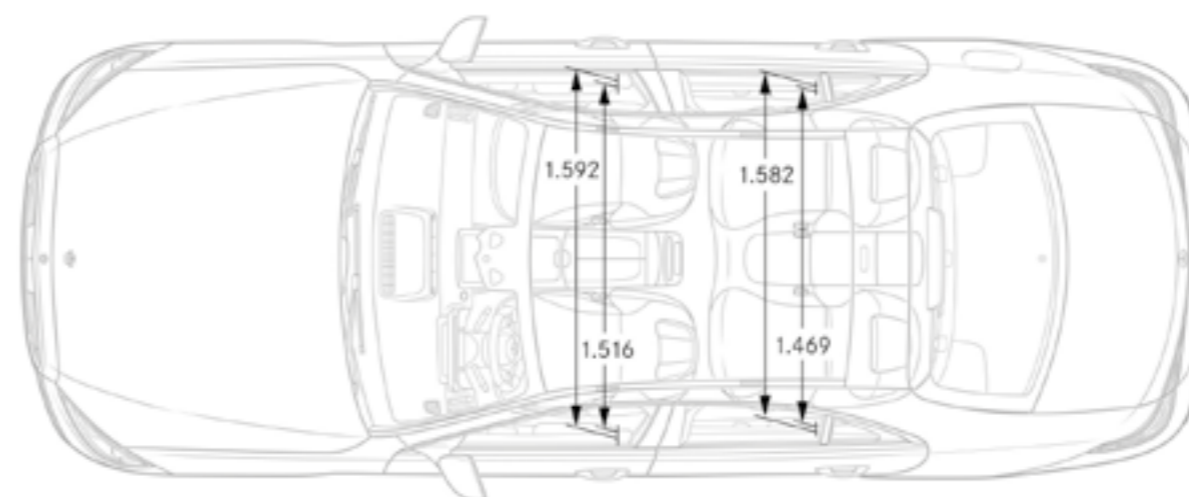
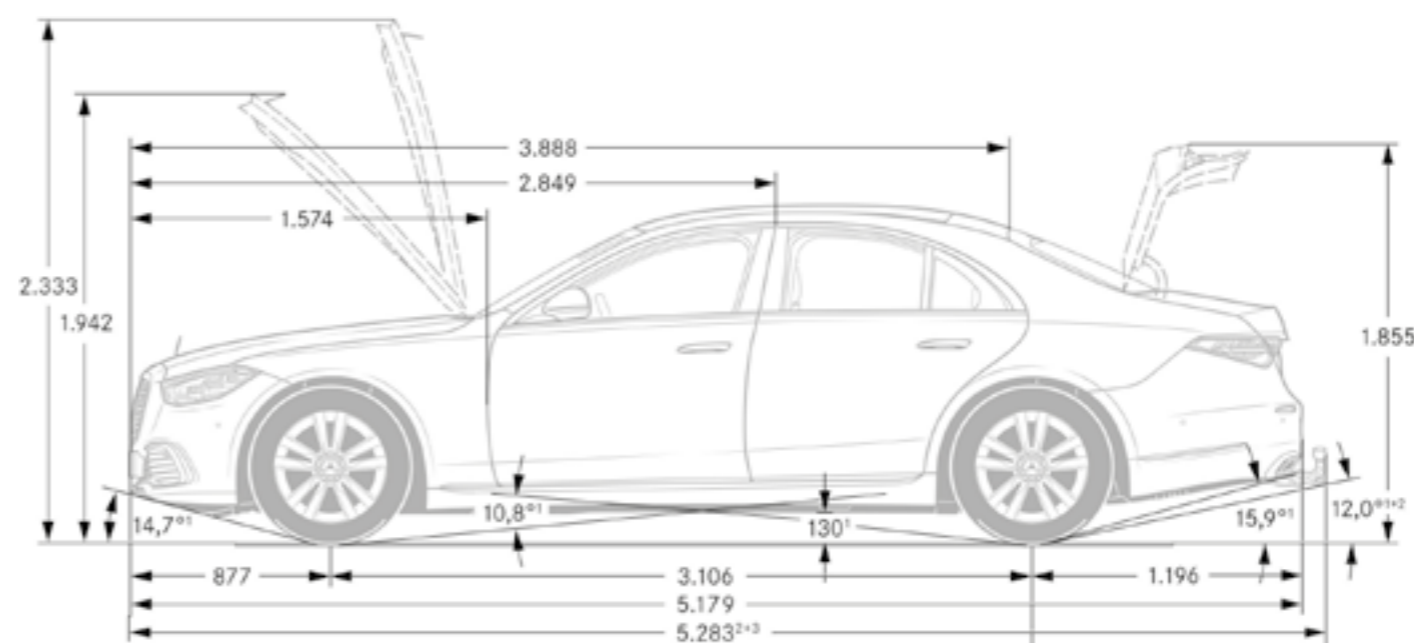
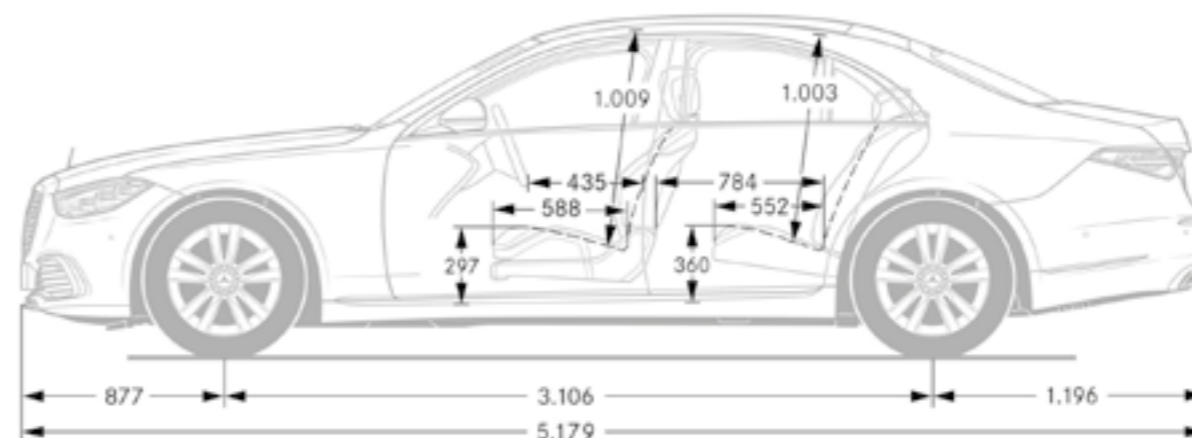
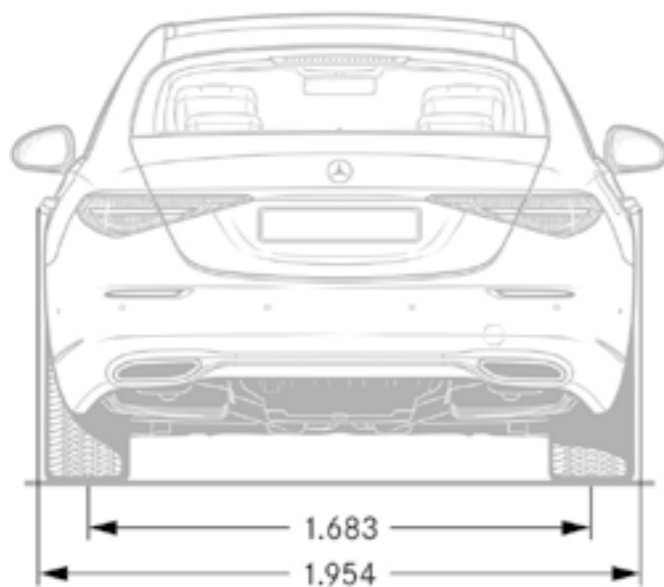
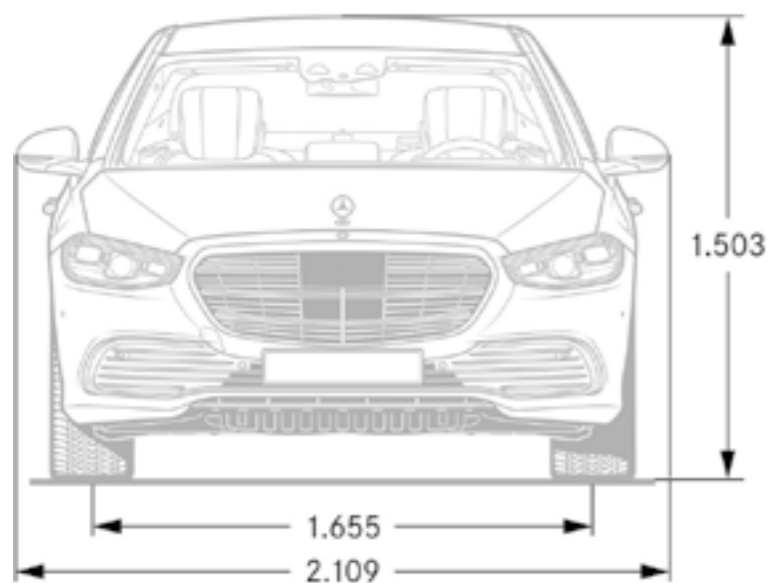

S-Klasse - lang Dimensioner

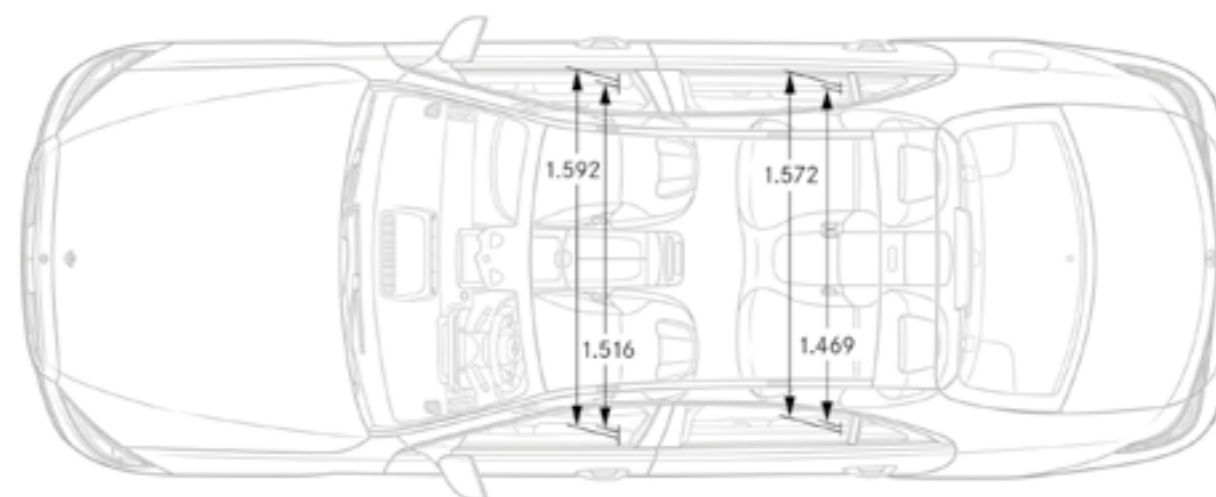
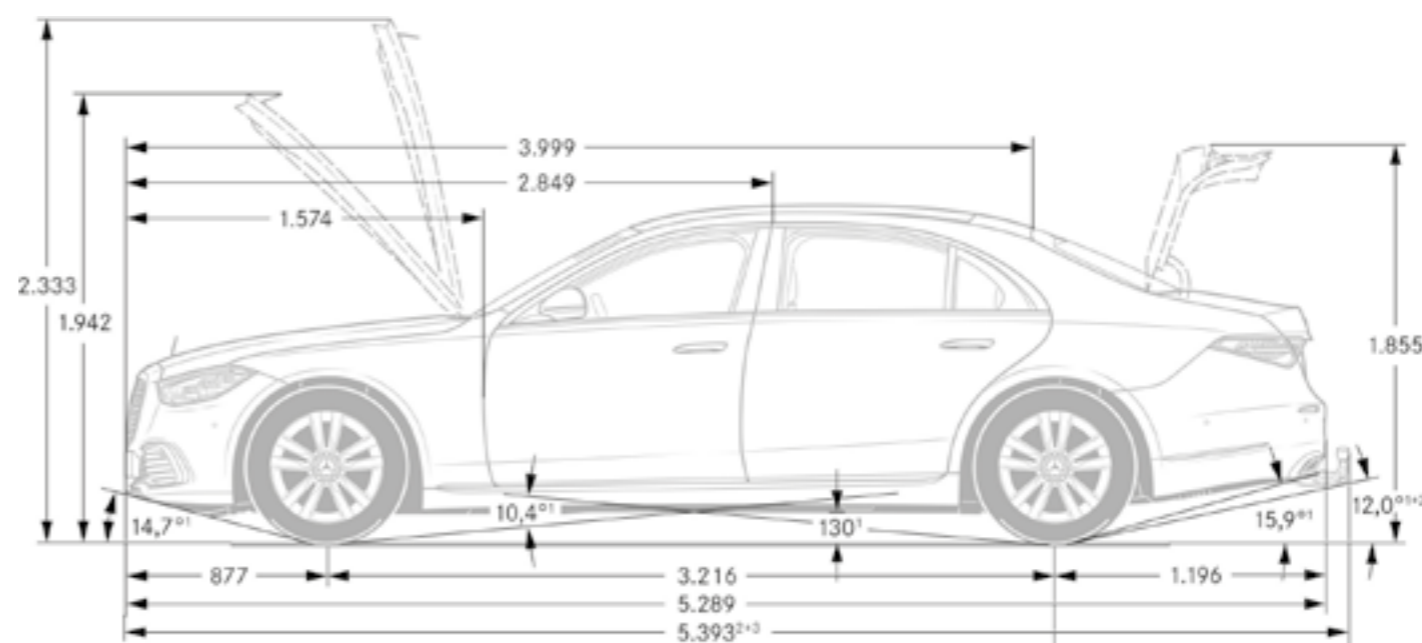
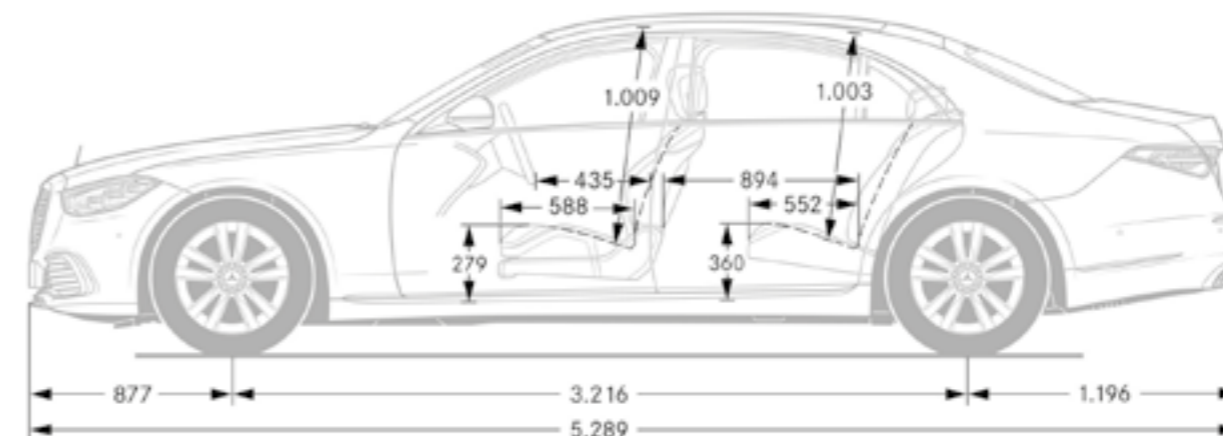
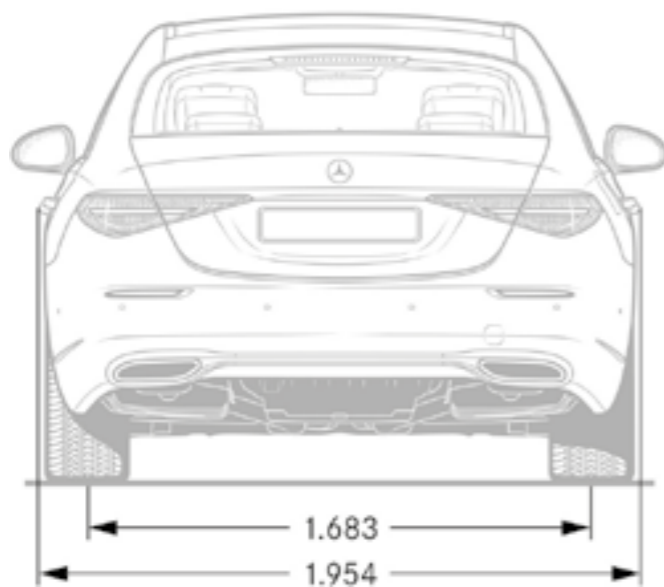
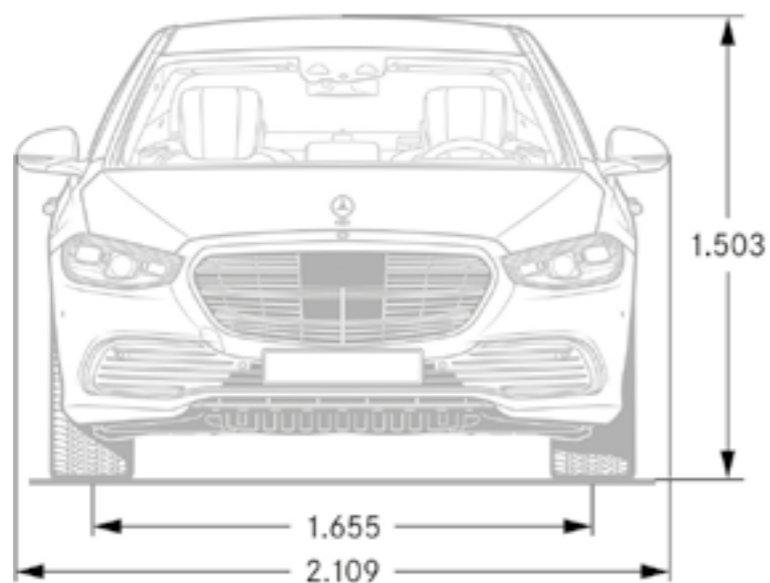

Gå yderligere på
opdagelse i online
konfiguratoren og byg
præcis din drømmebil!





me

mercedes-benz.com